



Monmouth County Park System

805 NEWMAN SPRINGS ROAD, LINCROFT, NJ 07738
www.monmouthcountyparks.com

Jennifer Kaczala, QPA
Phone: (732) 842-4000 Ext. 4217
Fax: (732) 842-4162

NOTICE OF REQUEST FOR PROPOSAL

The Monmouth County Park System is soliciting proposals through a Fair and Open process in accordance with the N.J.S.A. 19:44A-20.4 et seq.

Sealed RFP responses will be received by the Purchasing Agent on Tuesday, August 20, 2024 at 10:00 AM at the Park System Purchasing Department located at the Monmouth County Park System Headquarters, 805 Newman Springs Road, Lincroft, NJ 07738 at which time and place responses will be opened for:

FURNISHING, DELIVERY AND INSTALLATION OF CUSTOM TABLES (WC #05-24)

Specifications and instructions may be obtained at the Purchasing Office or on the Monmouth County Park System website, www.monmouthcountyparks.com.

Respondents shall comply with the requirements of Affirmative Action P.L. 1975 C127 (N.J.S.A. 17:27 et seq.). Statement of Ownership (N.J.S.A. 52:25 – 24.2) is required with your proposal. A copy of your New Jersey Business Registration is preferred with the proposal but mandatory prior to award of contract.

Jennifer Kaczala, QPA
Purchasing Agent



THE NATION'S FIRST ACCREDITED PARK AND RECREATION AGENCY

Serving the Citizens of Monmouth County Since 1961
RECYCLED PAPER

Specifications

(WC#05-24)

SPECIFICATIONS FOR THE FURNISHING, DELIVERY, AND INSTALLATION OF CUSTOM TABLES TO THE MONMOUTH COUNTY BOARD OF RECREATION COMMISSIONERS, LINCROFT, NEW JERSEY 07738

SCOPE: The purpose of this contract shall be to make available to the Monmouth County Park System-authorized sources for the procurement of CUSTOM TABLES as specified herein.

PROPOSAL:

The attached proposal must be submitted in order for bidders to be considered. Awards will be made to the vendor(s) offering the lowest net prices to the Monmouth County Park System. The Purchasing Committee reserves the right to accept or reject any or all bids in accordance with 40A:11-13.2 and to award in a manner in which is in their estimation to be in the best interest of the agency.

INSURANCE: The successful bidder shall maintain the following insurance coverage, and provide the Park System with a Certificate (ACCORD) of the same, within 21 business days of receiving notice of award of the contract:

- Certificate Holder – The holder of the Certificate of Insurance shall be the Board of Recreation Commissioners, 805 Newman Springs Road, Lincroft, NJ 07738.
- Additional Insured – The County of Monmouth must be named as additional insured on all policies, except the Worker’s Compensation policy.
- Worker’s Compensation and Employer’s Liability – Covers all the contractor’s employees engaged in the performance of the contract in accordance with the requirements of the laws of the State of New Jersey, including voluntary compensation/all states endorsement.
- General Liability – Covers bodily injury and property damage, including coverage for premises/operations; products/completed operations; broad form property damage; independent contractors; blanket contractual and, if applicable, explosion, collapse, and underground (XCU). Limits of not less than \$1,000,000.00 for both bodily injury and property damage are required. A combined single limit of \$1,000,000.00 is acceptable. The contractor shall maintain completed operations insurance for at least two years after the final payment.
- Comprehensive Automobile Liability – Covers bodily injury and property damage with limits of not less than \$1,000,000.00 per person or occurrence. A combined single limit of \$1,000,000.00 is acceptable. Coverage must include hired and non-owned vehicles. A MCS-90 certificate shall be filed with the State of New Jersey if hazardous materials or waste will be transported during the performance of the work.

- Builder's Risk Completed Value Form "All Risk" – The contractor shall obtain and maintain coverage for the entire work at the site to the full insurable value thereof.
- Subcontractors – The contractor's subcontracts shall impose and require its subcontractors to purchase and maintain insurance coverages identical to those set forth above.

METHOD OF AWARD: Award will be made to the responsive and responsible bidder offering the lowest total lump sum bid by the proposal.

PAYMENT: Upon completion of proposal, an invoice and a signed Monmouth County payment voucher must be submitted to the Board of Recreation Commissioners. Payment will be made upon approval of the voucher by the Monmouth County Board of Recreation Commissioners and the Monmouth County Board of Chosen Freeholders.

PREVAILING WAGE: The Contractor and all Subcontractors will be required to comply with the requirements of Chapter 150 of New Jersey Laws of 1963, known as the "New Jersey Prevailing Wage Act." Bidders, by submitting their Bids, pursuant to N.J.S.A. 34:11-56.38 (regarding the State of New Jersey list of debarred contractors and subcontractors), attest that neither they, their company, nor any of their proposed Subcontractors are prohibited from being awarded their Contracts for the Work for failure to pay Prevailing Wages. Regulations of the New Jersey Department of Labor (N.J.A.C. 12:60-1) require the Contractor and its subcontractors to submit certified payroll records to the Owner within ten days of the payment of wages. A copy of the certified payroll form for submission of payroll records may be obtained by contacting the New Jersey Department of Labor, Division of Workplace Standards. Current Prevailing Wage rates and list of debarred contractors are available online at:

<https://www.nj.gov/labor/wageandhour/prevailing-rates/public-works/index.shtml> Phone: 609-292-2283.

COMPLETION TIME: The successful bidder shall begin work only after receiving Notice to Proceed from the Park System. Work is to be completed within thirty (30) days of the award of the contract.

LOCATION: Thompson Park Visitor Center, Bldg. 501, Beech Room. 805 Newman Springs Road, Lincroft, NJ 07738

CONTACT INFORMATION: All questions regarding the work to be performed should be directed to:

Maryam Tronco

Maryam.Tronco@co.monmouth.nj.us

SPECIFICATIONS:

1. ITEM #1-TABLES

Custom rectangular meeting table in wood veneer. (Attached Drawing)

The top of the structure will be held up by two-panel bases. One of the long sides will feature a 12" high wood veneer modesty panel, 1.25" Thick, while the other side will have a 2" high apron.

- **Size:** 60" long, 24" wide, 30" high
- **Shape:** Rectangular
- **Top:** 1.25" thickness eased Edge / One Piece /Ling direction Grain
- **Quantity:** 6 tables
- **Castors:** 4 per table / Heavy Duty / 2" Diameter /not height adjustable
- No Power/No Data unit/No Wire
- **Finish:** Standard/Non-Premium/Satin sheen
- **Color:** Selected by Owner from manufacturer standard color samples. Submit samples illustrating the colors selected.

2. ITEM #2 – DELIVERY/INSTALLATION:

Six tables should be delivered and installed in the Beech room in the visitor center at Thompson Park. Installation should include placing them in the correct location in the room and any assembly if needed. The Park System is to be notified regarding the exact times of delivery. Park System reserves the right to count tables at the time of delivery. An authorized Park System representative must be present at the time of delivery . His/her signature will be the only signature recognized by the Park System in the event of lost or broken tables. Authorized representatives to sign for items at the visitor center is Maryam Tronco.

DRAWINGS:

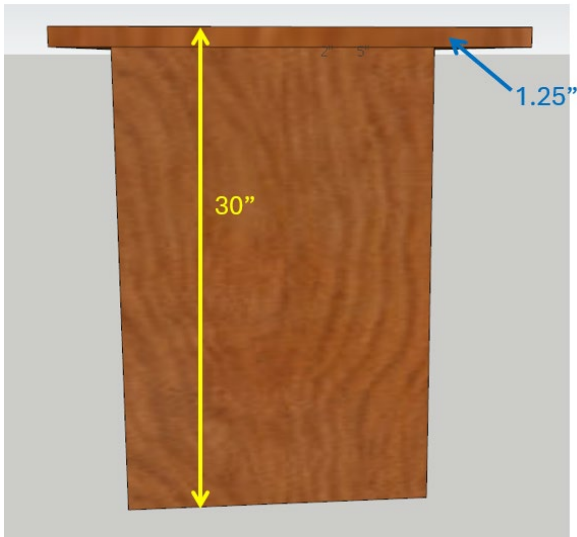
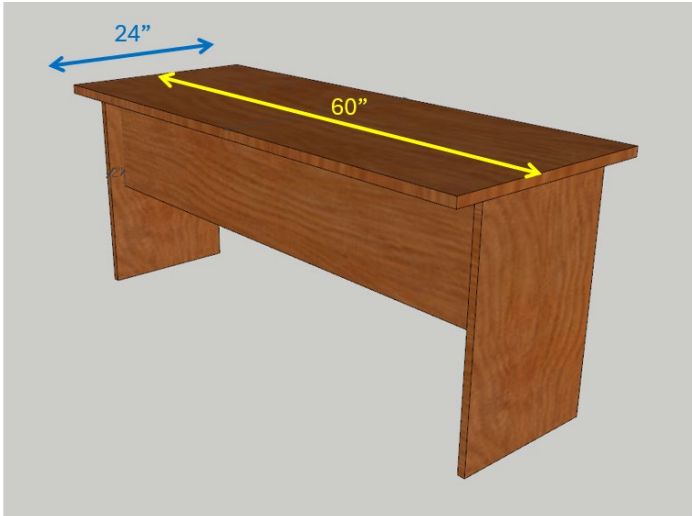

Side View

Top/Rear View

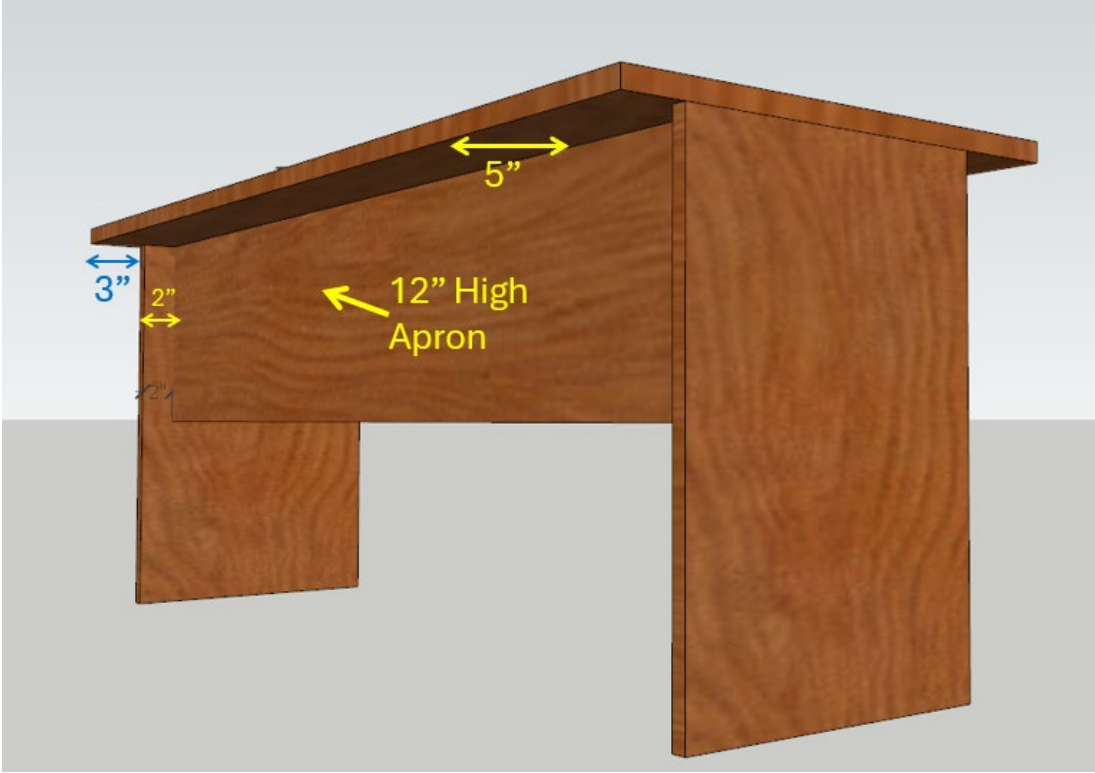

Rear View



Front View

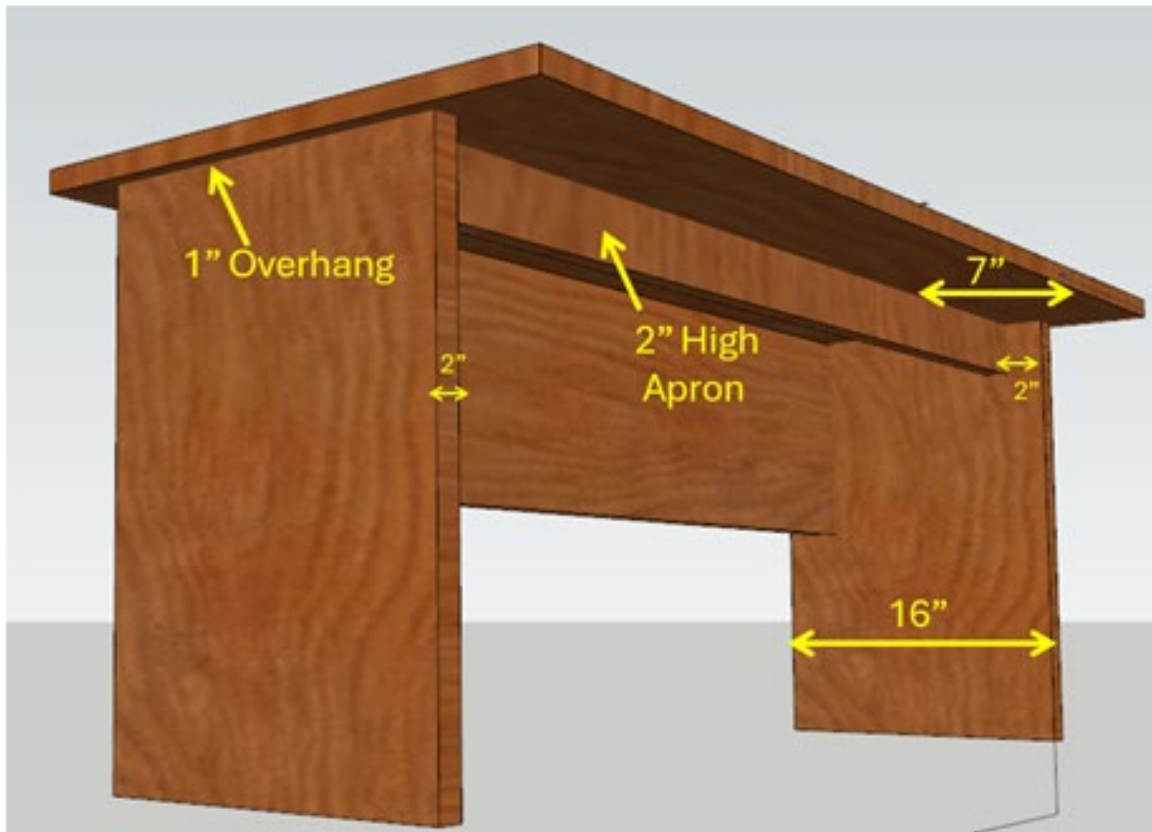

Front View

CONTRACT SAMPLE

“**Board**” means “Monmouth County Board of Recreation Commissioners”

“**Contractor**” means *{Insert Name of Vendor}* the legal entity with which the Board has entered into this Agreement, and its permitted successors and assigns.

“**Agreement**” means this *{Insert Title of Contract}* Agreement between the Board and the Contractor, dated *{Insert Award Date}*, as the same may be amended or modified from time to time in accordance herewith.

“**County**” means the County of Monmouth, New Jersey

This “**Agreement**” entered into this *{XX}* day of *{Month}*, 2021 by the “**Board**”, a body politic, with offices located at 805 Newman Springs Road, Lincroft, New Jersey 07738, and the “**Contractor**” a corporation with offices at *{Insert Vendor Address}*

IT IS AGREED:

- 1) Contractor will construct *{Insert Bid Title, BID #0000-00, BID DATE: 0/00/21}*, ITEMS: *{Insert Agenda Award Wording exactly from Award Form, Spell out Dollar Amount}* (\$ _____) all in accordance with the notice to bidders, plans, specifications and proposal, resolution awarding contract, and other bid documents, all of which are incorporated herein and made a part hereof as if set forth in full.
- 2) **Books and Records.** Contractor shall maintain all documentation related to products, transactions or services under this Agreement for a period of five years from the date of final payment. Such records shall be made available to the New Jersey Office of the State Comptroller upon request as per *N.J.A.C 17:44-2.2*
- 3) **Indemnification.** Contractor agrees that it will protect, indemnify and hold harmless the County of Monmouth, its Board of Recreation Commissioners, the Monmouth County Board of County Commissioners, Monmouth County Constitutional Officers (Sheriff, County Clerk, Prosecutor and Surrogate), and their respective employees, volunteers, and agents (together, the “County Indemnified Parties”), from and against (and pay the full amount of) all liabilities, obligations, delays, penalties, charges, taxes, fees and costs, deposits, actions, damages, claims, demands, judgments, losses, attorneys’ fees, expenses, and suits, and will defend the County Indemnified Parties in any suit, including appeals, for personal injury to, or death of, any person, or loss or damage to property, arising out of (1) actual or alleged negligence, intentional, or wrongful conduct of the Contractor or any of its officers, members, employees, agents, representatives, or subcontractors in connection with its obligations or rights under this Agreement, (2) actual or alleged Contractor breach, (3) actual or alleged performance or non-performance of the Contractor’s obligations under this Agreement, or (4) the Contractor’s actual or alleged failure to pay its workers, suppliers, or subcontractors for labor or materials provided to the Board. The Contractor’s indemnity obligations hereunder shall not be limited by any coverage exclusions or other provisions in any insurance policy maintained by the Contractor which is intended to respond to such events. The Contractor’s indemnification obligation shall not include claims that are finally determined to result from the sole negligence or willful misconduct of the Board.

A County Indemnified Party shall promptly notify the Contractor of the assertion of any claim against it for which it is entitled to be indemnified hereunder, shall give the Contractor the opportunity to defend such claim, and shall not settle the claim without the approval of the

Contractor. The Contractor agrees that the County reserves its right to monitor and actively participate in the defense of any and all claims against the County, at its own expense, if, in its sole discretion, the County chooses to do so. These indemnification provisions are for the protection of the County Indemnified Parties only and shall not establish, of themselves, any liability to third parties. The provisions of this subsection shall survive termination of this Agreement.

- 4) Counterparts. This Agreement may be fully executed in any number of counterparts, each of which shall be deemed to be an original and all of which taken together shall constitute one agreement binding upon all parties, notwithstanding that all parties have not signed the same counterpart. Such executions may be transmitted to the parties electronically or by facsimile, and such electronic or facsimile execution shall have the same force and effect as an original signature.
- 5) Notices. Any notices that are provided pursuant to this Agreement shall be in writing (including facsimile and electronic transmissions) and mailed or transmitted or delivered as follows:

To the Board:
Monmouth County Board of Recreation Commissioners
805 Newman Springs Road
Lincroft, NJ 07738
Attn: Andrew J. Spears, Assistant Secretary-Director
Email: AndrewJ.Spears@co.monmouth.nj.us
Fax: 732-842-4162

with a copy to:

Jason Sena
Special County Counsel
Archer & Greiner, P.C.
10 Highway 35
Red Bank, NJ 07701

To the Contractor:

*XYZ Corp.
2 Main Street
Anytown, NJ 12345
Attn: Jane Doe, President
Email: jdoe@xyzcorp.com
Fax: 123-456-7890*

Or to such other address or individual as any party may from time to time notify the other.

- 6) Multi-Year Contracts. If the contract period extends beyond the Board's current budget year, the Agreement shall be subject to the availability and appropriation annually of sufficient funds in any subsequent year(s).

- 7) No Discrimination. The Contractor agrees to comply with the Anti-Discrimination in Employment requirements of N.J.S.A. 10:2-1, set forth in Exhibit A attached hereto. The Contractor also agrees to comply with the Equal Employment Opportunity requirements of N.J.S.A. 10:5-31 et seq. and N.J.A.C. 17:27 et seq., set forth in Exhibit B attached hereto. The Contractor also agrees to comply with the Americans with Disabilities Act requirements of 42 U.S.C. § 12101 et seq., set forth in Exhibit C attached hereto. The Contractor shall not discriminate nor permit discrimination by any of its officers, employees, agents, representatives, or subcontractors against any person because of age, race, color, religion, national origin, sex, creed, religion, ancestry, marital status, affectional or sexual orientation, familial status, disability, nationality, gender identity or, with respect to otherwise qualified individuals, disability. The Contractor will take all actions reasonably necessary to ensure that qualified applicants are employed, and that employees are treated during employment, without regard to their age, race, color, religion, national origin, sex, creed, religion, ancestry, marital status, affectional or sexual orientation, familial status, disability, nationality, gender identity or, with respect to otherwise qualified individuals, disability. Such action shall include, without limitation, recruitment, and recruitment advertising; layoff or termination; upgrading, demotion, transfer, rates of pay or other form of compensation; and selection for training, including apprenticeship. The Contractor shall impose these non-discrimination provisions by contract on all subcontractors hired to perform work related to this Agreement and shall take all reasonable actions necessary to enforce such provisions. The Contractor will post in conspicuous places, available to employees and applicants for employment, notices setting forth the provisions of this nondiscrimination clause.
- 8) New Jersey Business Registration. The Contractor has previously provided the Board with a copy of the Contractor's New Jersey Business Registration Certificate and that of any named subcontractor, verifying that the Contractor and subcontractors are properly registered with the New Jersey Department of the Treasury. The Contractor acknowledges that:
- (i) N.J.S.A. 52:32-44 imposes the following requirements on contractors and all subcontractors that knowingly provide goods or perform services for a contractor fulfilling this contract: 1) a subcontractor named in a bid or other proposal made by a contractor to a contracting agency shall provide a copy of its business registration to the contractor who shall provide it to the contracting agency; 2) the contractor shall maintain and submit to the contracting agency a list of subcontractors and their addresses that may be updated from time to time during the course of the contract performance; 3) prior to receipt of final payment from a contracting agency, the contractor must submit to the contracting agency a complete and accurate list of all subcontractors or attest that none was used; 4) during the term of this contract, the contractor and its affiliates shall collect and remit, and shall notify all subcontractors and their affiliates that they must collect and remit to the Director, New Jersey Division of Taxation, the use tax due pursuant to the Sales and Use Tax Act, (N.J.S.A. 54:32B-1 et seq.) on all taxable sales of tangible personal property delivered into this State.
- (ii) A contractor or subcontractor who fails to provide proof of business registration or provides false business registration information shall be liable to a penalty of \$25 for each day of violation, not to exceed \$50,000 for each business registration not properly provided or maintained under a contract with a contracting agency. Information on the law and its requirements is available by calling (609) 292-9292.
- 9) Annual Campaign Contribution Disclosure Requirements. Pursuant to N.J.S.A.19:44A-20.27, Any business entity making a contribution of money or any other thing of value, including an in-kind contribution, or pledge to make a contribution of any kind to a candidate

for or the holder of any public office having ultimate responsibility for the awarding of public contracts, or to a political party committee, legislative leadership committee, political committee or continuing political committee, which has received in any calendar year \$50,000 or more in the aggregate through agreements or contracts with a public entity, shall file an annual disclosure statement with the New Jersey Election Law Enforcement Commission, established pursuant to section 5 of P.L.1973, c.83 (C.19:44A-5), setting forth all such contributions made by the business entity during the 12 months prior to the reporting deadline.

- 10) Incorporation of Bid Specifications. The specific duties of the Contractor shall be as set forth in the Bid, Contract Documents which is incorporated in its entirety and made a part of this Agreement and attached hereto as Exhibit "XX". Should there occur a conflict between the description of the scope of work set forth in this Agreement and the Bid, this Agreement shall prevail.

The Contractor agrees that it has or will comply with, and where applicable shall continue throughout the period of this Agreement to comply with, all of the requirements of the Bid.

- 11) "Or Equal" Substitutions. Whenever these specifications identify a brand name, trade name or a manufacturer's name, this designation is used for classification or descriptive purposes only, and the bidder may substitute an equal product, subject to the approval of the Board.
- 12) Governing Law. This Agreement shall be governed by and construed in accordance with laws of the State of New Jersey.
- 13) Severability. In the event that a court of competent jurisdiction finds any term or clause in this Agreement to be invalid, unenforceable, or illegal, the same will not have an impact on other terms or clauses in the Agreement or the entire Agreement. Rather, such term or clause shall be regarded as stricken while the remainder of this Agreement shall continue to be in full effect. Such invalid, unenforceable, or illegal term or clause may be revised to the extent required to render the Agreement enforceable or valid, and the rights and responsibilities of the parties shall be interpreted and enforced accordingly, so as to preserve their agreement and intent to the fullest possible extent.
- 14) Compliance with Applicable Law. The Contractor shall, and shall cause all subcontractors to, perform in accordance with Applicable Law. The Contractor shall provide all notices, reports, and submissions required by Applicable Law. In the event that revisions in laws, rules, regulations, or other Applicable Law requires changes to the Contractor's performance under the Agreement, the Contractor shall comport with these updated requirements of Applicable Law.
 - "Applicable Law" means any law, rule, regulation, requirement, guideline, action, determination, or order of, or legal entitlement issued or deemed to be issued by, any federal, state, or local agency, court or other governmental body having jurisdiction, applicable from time-to-time regarding any transaction or matter contemplated by this Agreement.
- 15) No Third-Party Beneficiaries. Nothing in this Agreement is intended to confer on any person other than the parties hereto and their respective permitted successors and assigns hereunder any rights or remedies under or by reason of this Agreement.
- 16) No Waivers. No action of the Board or Contractor pursuant to this Agreement (including, but not limited to, any investigation or payment), and no failure to act, shall constitute a waiver by either party of the other party's obligation to comply with any term or provision of this Agreement. No course of dealing or delay by the Board or Contractor in exercising any

right, power or remedy under this Agreement shall operate as a waiver thereof or otherwise prejudice such party's rights, powers, and remedies.

- 17) No Consequential or Punitive Damages. In no event shall either party hereto be liable to the other or obligated in any manner to pay to the other any special, incidental, consequential, punitive, or similar damages (but not actual or direct damages) based upon claims arising out of or in connection with the performance or non-performance of its obligations or otherwise under this Agreement, whether such claims are based upon contract, tort, negligence, warranty or other legal theory. The waiver of the foregoing damages applies only to disputes and claims as between the Board and the Contractor. Nothing in this paragraph shall limit the obligation of the Contractor to indemnify, defend and hold harmless the Board Indemnified Parties for any special, incidental, consequential, punitive, or similar damages payable to third parties resulting from any act or circumstance for which the Contractor is obligated to indemnify the County Indemnified Parties in accordance with and to the extent provided hereunder.
- 18) Forum for Litigation. It is the express intention of the parties that all legal actions and proceedings related to this Agreement or to any rights or any relationship between the parties arising therefrom shall be commenced before the Superior Court of New Jersey, venued in Monmouth County; provided, however, that when circumstances allow for federal jurisdiction (based on diversity of citizenship or otherwise), such legal actions and proceedings may be maintained in federal court having jurisdiction over the Board. The Contractor irrevocably consents to the jurisdiction of such courts in any such actions or proceedings, and the Contractor waives any objection it may have to the laying of the jurisdiction of any such action or proceeding.
- 19) Assignment. This Agreement is not assignable or transferrable to any party other than the Contractor without the express written permission of the Board, which may be withheld in the Board's sole discretion for any reason, or for no reason at all. This restriction includes changes in ownership of the Contractor that exceed fifty percent (50%) of the equity or other applicable interests held and disclosed at the time of entry into this Agreement. Any such approval given in one instance shall not relieve the assigning party of its obligation to obtain the prior written approval of the other party to any further assignment. The approval of any assignment shall not operate to release either party from any of its obligations under this Agreement unless the written approval specifically provides otherwise. Any assignment of this Agreement shall require the assignee to assume the performance of and observe all obligations, representations, and warranties of the assigning party under this Agreement.
- 20) Amendments. Neither this Agreement nor any provision hereof may be changed, modified, amended, or waived except by written agreement duly executed by both parties.
- 21) Drafting Responsibility. Neither party shall be held to a higher standard than the other party in the interpretation or enforcement of this Agreement as a whole or any portion hereof as a result of having assumed primary drafting responsibility of this Agreement.
- 22) Acceptance of Final Payment. Acceptance of the final payment by the Contractor shall be considered a release in full of all claims against the Board arising out of, or by reason of, the work performed, and materials furnished under the Agreement.
- 23) Set-Off. Should Contractor either refuse or neglect to perform the service which Contractor is required to perform in accordance with the terms of this Agreement, and if expense is incurred by the Board by reason of Contractor's failure to perform, then and in that event, such expense shall be deducted from any payment due to Contractor. Exercise of such set-

off shall not operate to prevent the Board from pursuing any other remedy to which it may be entitled.

24) This Agreement may be terminated as follows:

- a. If Contractor is required to be licensed in order to perform the services which are the subject of this Agreement, then this Agreement may be terminated by the Board in the event that the appropriate governmental entity with jurisdiction has instituted an action to have the Contractor's license suspended or in the event that such entity has revoked or suspended said license. Notice of termination pursuant to this subparagraph shall be effective immediately upon the giving of said notice.
- b. If, through any cause, the Contractor, where applicable, shall fail to fulfill in timely and proper manner its obligations under this Agreement, or if the Contractor shall violate any of the covenants, agreements, or stipulations of this Agreement, the Board shall thereupon have the right to terminate this Agreement by giving written notice to the Contractor of such termination and specifying the effective date thereof. In such event, all finished or unfinished documents, data, studies, and reports prepared by the Contractor under this Agreement, shall be forthwith delivered to the Board.
- c. Bankruptcy or insolvency of the Contractor; sale of the business of the Contractor, or death or permanent disability of the Contractor in the event the Contractor is an individual.
- d. Should the Board default in the performance of this Agreement or materially breach any of its provisions, which remain uncured after thirty (30) days after notice is given to the Board, the Contractor may terminate this Agreement, unless the Board is prevented from performing this Agreement by circumstances beyond its control. In that instance, any obligations owing by the Board to the Contractor shall be suspended without liability for the period during which the Board is so prevented.
- e. Should the Board fail to pay Contractor all or any part of the compensation earned for services rendered within sixty (60) days after the date due, the Contractor may at its option, terminate this Agreement.
- f. Notwithstanding the above, the Contractor, where applicable, shall not be relieved of liability to the Board for damages sustained by the Board by virtue of any breach of the Agreement by the Contractor, and the Board may withhold any payments to the Contractor for the purpose of set off until such time as the exact amount of damages due to the Board from the Contractor is determined.
- g. Termination shall not operate to affect the validity of the indemnification provisions of this Agreement.

25) Insurance Coverage. The Contractor shall obtain, pay for, and maintain the insurance coverages listed in paragraphs (a) through (e) below with respect to performance of the Agreement. The Contractor shall be responsible for premiums, fees and other costs associated with obtaining and maintaining such required insurance, and the Board shall have no obligation to reimburse the Contractor therefor. The Board reserves the right to waive or modify the below requirements, if appropriate.

- (a) Statutory workers compensation insurance required to be held by any State or Federal law, including other states coverage, and employers liability coverage with limits of \$500,000 each accident, \$500,000 each employee and \$500,000 aggregate for disease;

- (b) Commercial General Liability coverage for bodily injury, property damage, and personal injury liability of not less than \$1,000,000 combined single limit each occurrence or offense, and \$2,000,000 general aggregate. Coverage is to include premises and operations, independent contractors, and products and completed operations;
- (c) Business Automobile Liability insurance including coverage for any owned, hired, or non-owned vehicle, with limits of not less than \$1,000,000 combined single limit, including an MCS 90 endorsement;
- (d) Umbrella excess or excess liability insurance above the required commercial general, business automobile, and employers liability insurance in the amount of \$1,000,000 each occurrence and aggregate; and

Additional Insureds. The Contractor shall name the County of Monmouth, Monmouth County Board of Recreation Commissioners, and their respective officers, servants, and agents as additional insureds (the "Additional Insureds") on all insurance policies required pursuant to this Appendix A (other than paragraphs 1(a) and (c) hereof).

To the extent permitted by Applicable Law, and by the insurance policies, each party shall waive the subrogation rights of its various insurance carriers in favor of the other party.

Insurance Certificates. Insurance, and any renewals thereof, shall be evidenced by certificates of insurance issued or countersigned by a duly authorized representative of the issuer and delivered to the Board for its approval.

Notices. Each insurance policy shall be endorsed to require 45 days written notice to the Board of cancellation, or intent not to renew by the insurance company.

Non-Recourse Provision. All insurance policies shall provide that the insurers shall have no recourse against the Additional Insured for payment of any premium or assessment and shall contain a severability of interest provision in regard to mutual coverage liability policies. The coverages provided by mutual coverage liability insurance policies required hereunder shall be the primary source of any restitution or other recovery for any injuries to or death of persons or loss or damage to property incurred as a result of an action or inaction of the Contractor or its subcontractors, of their respective suppliers, employees, agents, representatives, or invitees, that fall within these coverages and also within the coverages of any liability insurance or self-insurance program maintained by the Board.

Subcontractors. The Contractor shall be responsible for ensuring that all subcontractors that are providing contract services secure and maintain all insurance coverages (including workers' compensation insurance) and other financial sureties required by New Jersey law in connection with their presence and the performance of their duties at or concerning the providing of contract services.

Qualifications of Insurers. The Contractor is required to obtain the insurance set forth herein with insurance companies allowed to do business in the State of New Jersey, which maintain ratings of at least A- VII in the latest evaluation of the A.M. Best Contractor Reports.

26) Liquidated Damages. This Agreement provides for the payment of liquidated damages in certain circumstances of nonperformance, breach, and default. Each party agrees that the damaged party's actual damages in each such circumstance would be difficult or impossible to ascertain and that the liquidated damages provided for herein with respect to each such circumstance are intended to place the damaged party in the same economic position as it would have been in had the circumstance not occurred. Except as otherwise specifically provided herein, such liquidated damages shall constitute the only remedy in such circumstances by the nonperforming, breaching, or defaulting party, regardless of legal theory.

IN WITNESS WHEREOF, the parties have signed this agreement.

MONMOUTH COUNTY BOARD
OF RECREATION COMMISSIONERS

{VENDOR NAME}

BY: _____
Kevin Mandeville, Chairman

BY: _____

ATTEST:

Andrew J. Spears, Director

ATTEST:

DATE: _____

DATE: _____

RESOLUTION NO: _____

PURCHASE ORDER NO: _____

PUBLIC WORKS CONTRACTOR REGISTRATION ACT:

Public Works Contractor Registration Act: The Public Works Contractor Registration Act (P.L.1999, c238 as amended by P.L. 2003, c91). No contractor shall bid on any contract for public work as defined in section 2 of P.L. 1963, c.150 (C.34:11-56.26) unless the contractor is registered pursuant to this act. No contractor shall list a subcontractor in a bid proposal for the contract unless the subcontractor is registered pursuant to P.L. 1999, c.238 (C.34:11-56.48 et seq.) at the time the bid is made. No contractor or subcontractor, including a subcontractor not listed in the bid proposal, shall engage in the performance of any public work subject to the contract, unless the contractor or subcontractor is registered pursuant to that act.

PREVAILING WAGE:

The Contractor and all Subcontractors will be required to comply with the requirements of Chapter 150 of New Jersey Laws of 1963, known as the "New Jersey Prevailing Wage Act."

Bidders, by submitting their Bids, pursuant to N.J.S.A. 34:11-56.38 (regarding the State of New Jersey list of debarred contractors and subcontractors), attest that neither they, their company, nor any of their proposed Subcontractors are prohibited from being awarded their Contracts for the Work for failure to pay Prevailing Wages.

Regulations of the New Jersey Department of Labor (N.J.A.C. 12:60-1) require the Contractor and its subcontractors to submit certified payroll records to the Owner within ten days of the payment of wages. A copy of the certified payroll form for submission of payroll records may be obtained by contacting the New Jersey Department of Labor, Division of Workplace Standards.

Current Prevailing Wage rates and list of debarred contractors are available online at:

https://www.nj.gov/labor/wagehour/wagerate/pwr_construction.html

Phone: 609-292-2283

BIDDER'S CHECKLIST

WC # 05-24

(Owner's checkmarks)		Items submitted with bid (Bidder's INITIALS)
⇓		⇓
<u> X </u>	Proposal	_____
<u> X </u>	Statement of Ownership	_____
<u> X </u>	Non-Collusion Affidavit	_____
<u> X </u>	Disclosure of Energy Sector Investment Activities in Iran	_____
<u> X </u>	Copy of the N.J. Business Registration Certificate for the bidder and any designated subcontractors	_____
<u> X </u>	EEO/Affirmative Action Compliance Notice or Valid EEO Certificate	_____
<u> X </u>	References / List of previous and/or active relevant work	_____
<u> X </u>	Current Public Works Certificate	_____

THE UNDERSIGNED BIDDER HEREWITH SUBMITS THE ABOVE REQUIRED DOCUMENTS:

COMPANY NAME: _____

SIGNED BY: _____

PRINT NAME AND TITLE: _____

DATE: _____

THIS CHECKLIST SHOULD BE INITIALED AND SIGNED WHERE INDICATED AND RETURNED WITH ALL DOCUMENTS

Proposal

(WC #05-24)

SUBMITTED BY: _____
(Company Name)

FURNISHING, DELIVERY, AND INSTALLATION OF CUSTOM TABLES
TO THE MONMOUTH COUNTY PARK SYSTEM, LINCROFT, NEW JERSEY.
TO THE MONMOUTH COUNTY BOARD OF RECREATION COMMISSIONERS.

The undersigned hereby declares that he has carefully examined the advertisement, specifications, and form of contract for furnishing the specified items and that - he will execute the contract according to the specifications, terms, and conditions with respect to the following:

ITEM NUMBER	ITEM DESCRIPTION	QTY.	UNIT COST	TOTAL COST
1	Tables	6	\$	\$
2	Delivery	1	\$	\$
Total Lump Sum Bid			\$	

PLEASE NOTE: N.J. TAX EXEMPTION NO. 69-0220842

VARIANCE IF ANY: _____

The undersigned is (circle one) - a partnership under the laws of the State of _____
- a corporation
- an individual

CONTRACTOR NAME: _____

CONTACT PERSON: _____

SIGNATURE: _____

ADDRESS: _____

BUSINESS PHONE: _____

FAX NO.: _____

CELL PHONE NO.: _____ DATE: _____

E-MAIL ADDRESS: _____

FEDERAL TAX ID# OR SOCIAL SECURITY# _____

CAUTION

REGARDING STATEMENT OF OWNERSHIP

The enclosed Statement of Ownership form must be properly completed. If it is not properly completed, your bid must be rejected, as required by N.J.S.A. 40A:11-23.2. **Mistakes cannot be cured after bids are received.**

For example, if your firm, bidder “A”, is entirely owned by corporation “B”, you must disclose the names and addresses of the owners of 10% or more of corporation “B”. Furthermore, if corporation “C” owns 10% or more of corporation “B”, you must disclose the names and addresses of the owners of 10% or more of corporation “C”, and so on, until the names and addresses of all persons, i.e., human beings, in this “10%” chain of ownership have been disclosed.

The same procedure applies if any 10% or more owner is a partnership, limited liability company, estate or any other type of legal entity, as opposed to a corporation.

STATEMENT OF OWNERSHIP

(N.J.S.A. 52:25-24.2)

The CONTRACTOR is (check one):

- | | | |
|--|--|--|
| <input type="checkbox"/> Partnership | <input type="checkbox"/> Corporation | <input type="checkbox"/> Sole Proprietorship |
| <input type="checkbox"/> Limited Liability Partnership | <input type="checkbox"/> Limited Liability Corporation | <input type="checkbox"/> Limited Partnership |
| <input type="checkbox"/> Subchapter S Corporation | <input type="checkbox"/> Other, Please List _____ | |

I certify that:

No individual person or entity owns a 10% or greater interest in the Contractor.

OR

The list below contains the names and home addresses of all stockholders holding 10% or more of the issued and outstanding stock of the Contractor. However if a parent entity holding 10% or more is a publicly traded entity, then the Contractor in complying with N.J.S.A. 52:25-24.2 may submit the name and address of each publicly traded entity, and the name and address of each person holding 10% or more beneficial interest in the publicly traded entity as of the last annual filing with the Security Exchange Commission (SEC), or foreign equivalent.

Name: _____ Address: _____

Name: _____ Address: _____

Name: _____ Address: _____

Check here if additional sheets are attached.

NOTE: If an entity owns a 10% or greater interest in the Contractor, list all owners of 10% or greater interest for each such entity. Repeat the process of disclosure as necessary for each tier or level of ownership until the name and address of each individual person who owns a 10% or greater interest in each listed entity has been disclosed.

Publicly Traded Parent Company Disclosure:

Provide the Website (URL) providing the last annual Security Exchange Commission (SEC) filing, or foreign equivalent:

The requested information is available on the following page number(s) of the SEC, or foreign equivalent, filing:

CONTRACTOR _____

SIGNED BY: X _____

PRINT NAME & TITLE: _____

DATE: _____

(Corporate seal if a corporation)

NON-COLLUSION AFFIDAVIT

(N.J.S.A. 52:34-15)

STATE OF _____) ss:

COUNTY OF _____)

Re: Furnishing, Delivery and Installation of Custom Tables (WC#05-24)

I, _____ (name)

of full age, being duly sworn according to law, on my oath depose and say:

I am the _____ (title)

of _____ (name of bidder), the bidder for the above named project, and that I executed the said bid with full authority so to do; that the bidder has not, directly or indirectly, entered into any agreement, participated in any collusion, or otherwise taken any action in restraint of free, competitive bidding in connection with the above named project; and that all statements contained in the bid and in this affidavit are true and correct, and made with full knowledge that the County of Monmouth relies upon the truth of the statements contained in the bid and in the statements contained in this affidavit in awarding a contract for the project.

I further warrant that no person or selling agency has been employed or retained to solicit or secure such contract upon an agreement or understanding for a commission, percentage, brokerage or contingent fee, except bona fide employees or bona fide established commercial or selling agencies maintained by my firm for the purpose of securing business.

Signed: X _____

Subscribed and sworn to

before me this _____ day

of _____, 20__.

Notary Public of

My commission expires _____, 20__.

Monmouth County Park System, County of Monmouth, State of New Jersey
Division of Purchasing

DISCLOSURE OF ENERGY SECTOR INVESTMENT ACTIVITIES IN IRAN
New Jersey Public Law 2012, Chapter 25

Solicitation Number: WC#05-24 **Bidder / Respondent:** _____

Project Title: Furnishing, Delivery and Installation of Custom Tables

PART 1 – CERTIFICATION – CHECK THE APPROPRIATE BOX:

A. I certify that neither the Bidder / Respondent nor any of the Bidder's / Respondent's parents, subsidiaries, or affiliates, as defined in C.52:32-56(e), is on the "Chapter 25 List" created and maintained by the New Jersey Department of the Treasury, as a person or entity engaging in the energy sector investment activities in Iran described in C.52:32-56(f). The Chapter 25 List may be found at <http://www.state.nj.us/treasury/purchase/pdf/Chapter25List.pdf>.

OR

B. The Bidder / Respondent and/or one or more of its parents, subsidiaries or affiliates is a person or entity on the Chapter 25 List referred to above. A detailed and precise description of the relevant activities of the listed Bidder / Respondent and/or listed parents, subsidiaries or affiliates is provided in Part 2 below.

PART 2 – ADDITIONAL INFORMATION – COMPLETE PART 2 ONLY IF B. IN PART 1 IS CHECKED:

The following is an accurate and precise description of the energy sector investment activities in Iran of the Bidder / Respondent and/or listed parents, subsidiaries or affiliates, on the Chapter 25 List (attach additional pages as necessary to make full disclosure):

Name of Person(s) or Entity(ies) on the Chapter 25 List: _____

Relationship to Bidder / Respondent: _____

Description of Activities: _____

Duration of Engagement: _____ Anticipated Cessation Date: _____

Bidder / Respondent Contact Name: _____ Contact Phone Number: _____

Check here if additional pages are attached and state number of attached pages: _____ (Number of pages attached.)

CERTIFICATION FOR PART 1 AND, IF APPLICABLE, PART 2: I, being of full age, hereby certify that the foregoing information and any attachments hereto are to the best of my knowledge true and complete. I certify that I am authorized to execute this certification on behalf of the Respondent. I acknowledge that the County of Monmouth will rely on the information contained herein and thereby acknowledge that I and the Bidder / Respondent are under a continuing obligation from the date of this certification through the completion of any contracts with the County to notify the County in writing of any changes to the answers or information contained herein.

I certify that the foregoing statements made by me are true. I am aware that if any of the foregoing statements made by me is willfully false, I am subject to punishment and the Bidder / Respondent is subject to the penalties stated in C. 52:32-59 and C. 40A:11-2.1.

Full Name (Print) _____ Signature: _____

Title: _____ Date: _____

NEW JERSEY BUSINESS REGISTRATION REQUIREMENTS GOODS, SERVICES, AND CONSTRUCTION* CONTRACTS

Proof of valid business registration (a Business Registration Certificate) with the New Jersey Department of Treasury, Division of Revenue must be submitted to the contracting agency prior to the award of any contract, including purchase orders. No contract will be awarded without proof of such business registration. N.J.S.A. 52:32-44 imposes the following requirements on contractors and on all subcontractors that knowingly enter into a contract, or construct a construction project, with a contractor in the fulfillment of a contract with a contracting agency. *In the case of a construction contract, “subcontractor” shall mean only designated subcontractors who are required by N.J.S.A. 40A:11-16 to be named in the submission of a bid.

A subcontractor named in a bid or other proposal made by a contractor to a contracting agency shall provide a copy of its business registration to the contractor who shall provide it to the contracting agency. The contractor shall provide the contracting agency with the business registration of the contractor and that of any named subcontractors prior to the time a contract is awarded.

The contractor shall maintain and submit to the contracting agency a list of subcontractors and their addresses that may be updated from time to time during the course of the contract performance. Before final payment of the contract is made by the contracting agency, the contractor shall submit a complete and accurate list and proof of business registration of each subcontractor or supplier used in the fulfillment of the contract, or shall attest that no subcontractors were used.

For the term of the contract, the contractor and each of its affiliates and each subcontractor and each of its affiliates (N.J.S.A. 52:32-44 (g) (3)) shall collect and remit to the Director, New Jersey Division of Taxation, the use tax due pursuant to the “Sales and Use Tax Act” (N.J.S.A. 54:32 B-1, et seq.) on all taxable sales of tangible personal property delivered into this state.

A business organization that fails to provide proof of business registration or provides false business registration information shall be liable to a penalty of \$25 for each day of violation, not to exceed \$50,000 for each business registration not properly provided or maintained under a contract with a contracting agency

Sample Business Registration Certificates are attached for convenience. Questions on obtaining a Business Registration Certificate or on the law and its requirements can be directed to the Division of Revenue at (609) 292-9292.

THESE ARE SAMPLES OF BUSINESS REGISTRATION CERTIFICATES.

	STATE OF NEW JERSEY BUSINESS REGISTRATION CERTIFICATE
Taxpayer Name:	
Trade Name:	
Address:	
Certificate Number:	
Date of Issuance:	
For Office Use Only:	

OR

STATE OF NEW JERSEY BUSINESS REGISTRATION CERTIFICATE		DEPARTMENT OF TREASURY DIVISION OF REVENUE P.O. BOX 282 TRENTON, N.J. 08646-0282
TAXPAYER NAME:	TRADE NAME:	
TAXPAYER IDENTIFICATION#:	SEQUENCE NUMBER:	
ADDRESS:	ISSUANCE DATE:	
EFFECTIVE DATE:		
FORM-BRC(08-01)	<small>Att. Director</small>	<small>This Certificate is NOT assignable or transferable. It must be prominently displayed at above address.</small>

(Revised 5/2017)

EXHIBIT A

MANDATORY ANTI-DISCRIMINATION IN EMPLOYMENT LANGUAGE N.J.S.A. 10:2-1

CONSTRUCTION, ALTERATION OR REPAIR OF ANY PUBLIC BUILDING OR PUBLIC WORK OR FOR THE ACQUISITION OF MATERIALS, EQUIPMENT, SUPPLIES OR SERVICES CONTRACTS

During the performance of this contract, the contractor agrees as follows:

In the hiring of persons for the performance of work under this contract or any subcontract hereunder, or for the procurement, manufacture, assembling or furnishing of any such materials, equipment, supplies or services to be acquired under this contract, no contractor, nor any person acting on behalf of such contractor or subcontractor, shall, by reason of race, creed, color, national origin, ancestry, marital status, gender identity or expression, affectional or sexual orientation or sex, discriminate against any person who is qualified and available to perform the work to which the employment relates.

No contractor, subcontractor, nor any person on his behalf shall, in any manner, discriminate against or intimidate any employee engaged in the performance of work under this contract or any subcontract hereunder, or engaged in the procurement, manufacture, assembling or furnishing of any such materials, equipment, supplies or services to be acquired under such contract, on account of race, creed, color, national origin, ancestry, marital status, gender identity or expression, affectional or sexual orientation or sex.

There may be deducted from the amount payable to the contractor by the contracting public agency, under this contract, a penalty of \$50.00 for each person for each calendar day during which such person is discriminated against or intimidated in violation of the provisions of the contract.

This contract may be canceled or terminated by the contracting public agency, and all money due or to become due hereunder may be forfeited, for any violation of this section of the contract occurring after notice to the contractor from the contracting public agency of any prior violation of this section of the contract.

No provision in this section shall be construed to prevent a board of education from designating that a contract, subcontract or other means of procurement of goods, services, equipment or construction shall be awarded to a small business enterprise, minority business enterprise or a women's business enterprise pursuant to P.L. 1985, c. 490 (C.18A:18A-51 et seq.).

EXHIBIT B

MANDATORY EQUAL EMPLOYMENT OPPORTUNITY LANGUAGE *N.J.S.A. 10:5-31 et seq. (P.L. 1975, c. 127)* *N.J.A.C. 17:27 et seq.*

GOODS, GENERAL SERVICES, AND PROFESSIONAL SERVICES CONTRACTS

During the performance of this contract, the contractor agrees as follows:

The contractor or subcontractor, where applicable, will not discriminate against any employee or applicant for employment because of age, race, creed, color, national origin, ancestry, marital status, affectional or sexual orientation, gender identity or expression, disability, nationality or sex. Except with respect to affectional or sexual orientation and gender identity or expression, the contractor will ensure that equal employment opportunity is afforded to such applicants in recruitment and employment, and that employees are treated during employment, without regard to their age, race, creed, color, national origin, ancestry, marital status, affectional or sexual orientation, gender identity or expression, disability, nationality or sex. Such equal employment opportunity shall include, but not be limited to the following: employment, upgrading, demotion, or transfer; recruitment or recruitment advertising; layoff or termination; rates of pay or other forms of compensation; and selection for training, including apprenticeship. The contractor agrees to post in conspicuous places, available to employees and applicants for employment, notices to be provided by the Public Agency Compliance Officer setting forth provisions of this nondiscrimination clause.

The contractor or subcontractor, where applicable will, in all solicitations or advertisements for employees placed by or on behalf of the contractor, state that all qualified applicants will receive consideration for employment without regard to age, race, creed, color, national origin, ancestry, marital status, affectional or sexual orientation, gender identity or expression, disability, nationality or sex.

The contractor or subcontractor will send to each labor union, with which it has a collective bargaining agreement, a notice, to be provided by the agency contracting officer, advising the labor union of the contractor's commitments under this chapter and shall post copies of the notice in conspicuous places available to employees and applicants for employment.

The contractor or subcontractor, where applicable, agrees to comply with any regulations promulgated by the Treasurer pursuant to *N.J.S.A. 10:5-31 et seq.*, as amended and supplemented from time to time and the Americans with Disabilities Act.

The contractor or subcontractor agrees to make good faith efforts to meet targeted county employment goals established in accordance with *N.J.A.C. 17:27-5.2*.

The contractor or subcontractor agrees to inform in writing its appropriate recruitment agencies including, but not limited to, employment agencies, placement bureaus, colleges, universities, and labor unions, that it does not discriminate on the basis of age, race, creed, color, national origin, ancestry, marital status, affectional or sexual orientation, gender identity or expression, disability, nationality or sex, and that it will discontinue the use of any recruitment agency which engages in direct or indirect discriminatory practices.

The contractor or subcontractor agrees to revise any of its testing procedures, if necessary, to assure that all personnel testing conforms with the principles of job-related testing, as established by the statutes and court decisions of the State of New Jersey and as established by applicable Federal law and applicable Federal court decisions.

In conforming with the targeted employment goals, the contractor or subcontractor agrees to review all procedures relating to transfer, upgrading, downgrading and layoff to ensure that all such actions are taken without regard to age, race, creed, color, national origin, ancestry, marital status, affectional or sexual orientation, gender identity or expression, disability, nationality or sex, consistent with the statutes and court decisions of the State of New Jersey, and applicable Federal law and applicable Federal court decisions.

The contractor shall submit to the public agency, after notification of award but prior to execution of a goods and services contract, one of the following three documents:

- Letter of Federal Affirmative Action Plan Approval
- Certificate of Employee Information Report
- Employee Information Report Form AA-302 (electronically provided by the Division of Purchase & Property, CCAU, EEO Monitoring Program and distributed to the public agency through the Division of Purchase & Property, CCAU, EEO Monitoring Program's website at www.state.nj.us/treasury/contract_compliance/)

The contractor and its subcontractors shall furnish such reports or other documents to the Division of Purchase & Property, CCAU, EEO Monitoring Program as may be requested by the office from time to time in order to carry out the purposes of these regulations, and public agencies shall furnish such information as may be requested by the Division of Purchase & Property, CCAU, EEO Monitoring Program for conducting a compliance investigation pursuant to *N.J.A.C. 17:27-1.1 et seq.*

EXHIBIT C

AMERICANS WITH DISABILITIES ACT OF 1990 Equal Opportunity for Individuals with Disability

The contractor and the County of Monmouth, (hereafter "owner") do hereby agree that the provisions of Title 11 of the Americans With Disabilities Act of 1990 (the "Act") (42 U.S.C. §12101 et seq.), which prohibits discrimination on the basis of disability by public entities in all services, programs, and activities provided or made available by public entities, and the rules and regulations promulgated pursuant there unto, are made a part of this contract. In providing any aid, benefit, or service on behalf of the owner pursuant to this contract, the contractor agrees that the performance shall be in strict compliance with the Act. In the event that the contractor, its agents, servants, employees, or subcontractors violate or are alleged to have violated the Act during the performance of this contract, the contractor shall defend the owner in any action or administrative proceeding commenced pursuant to this Act. The contractor shall indemnify, protect, and save harmless the owner, its agents, servants, and employees from and against any and all suits, claims, losses, demands, or damages, of whatever kind or nature arising out of or claimed to arise out of the alleged violation. The contractor shall, at its own expense, appear, defend, and pay any and all charges for legal services and any and all costs and other expenses arising from such action or administrative proceeding or incurred in connection therewith. In any and all complaints brought pursuant to the owner's grievance procedure, the contractor agrees to abide by any decision of the owner which is rendered pursuant to said grievance procedure. If any action or administrative proceeding results in an award of damages against the owner, or if the owner incurs any expense to cure a violation of the ADA which has been brought pursuant to its grievance procedure, the contractor shall satisfy and discharge the same at its own expense.

The owner shall, as soon as practicable after a claim has been made against it, give written notice thereof to the contractor along with full and complete particulars of the claim. If any action or administrative proceeding is brought against the owner or any of its agents, servants, and employees, the *owner shall* expeditiously forward or have forwarded to the contractor every demand, complaint, notice, summons, pleading, or other process received by the owner or its representatives.

It is expressly agreed and understood that any approval by the owner of the services provided by the contractor pursuant to this contract will not relieve the contractor of the obligation to comply with the Act and to defend, indemnify, protect, and save harmless the owner pursuant to this paragraph.

It is further agreed and understood that the owner assumes no obligation to indemnify or save harmless the contractor, its agents, servants, employees and subcontractors for any claim which may arise out of their performance of this Agreement. Furthermore, the contractor expressly understands and agrees that the provisions of this indemnification clause shall in no way limit the contractor's obligations assumed in this Agreement, nor shall they be construed to relieve the contractor from any liability, nor preclude the owner from taking any other actions available to it under any other provisions of the Agreement or otherwise at law.

(Revised 2/2017)

EEO/AFFIRMATIVE ACTION COMPLIANCE NOTICE
N.J.S.A. 10:5-31 and N.J.A.C. 17:27
GOODS, PROFESSIONAL SERVICE AND GENERAL SERVICE CONTRACTS

All successful bidders are required to submit evidence of appropriate affirmative action compliance to the County and Division of Public Contracts Equal Employment Opportunity Compliance. During a review, Division representatives will review the County files to determine whether the affirmative action evidence has been submitted by the vendor/contractor. Specifically, each vendor/contractor shall submit to the Commission, prior to execution of the contract, one of the following documents:

Goods and General Service Vendors

1. Letter of Federal Approval indicating that the vendor is under an existing Federally approved or sanctioned affirmative action program. A copy of the approval letter is to be provided by the vendor to the Commission and the Division. This approval letter is valid for one year from the date of issuance.

Do you have a federally-approved or sanctioned EEO/AA program? Yes No
If yes, please submit a photostatic copy of such approval.

2. A Certificate of Employee Information Report (hereafter "Certificate"), issued in accordance with N.J.A.C. 17:27-1.1 et seq. The vendor must provide a copy of the Certificate to the Commission as evidence of its compliance with the regulations. The Certificate represents the review and approval of the vendor's Employee Information Report, Form AA-302 by the Division. The period of validity of the Certificate is indicated on its face. Certificates must be renewed prior to their expiration date in order to remain valid.

Do you have a State Certificate of Employee Information Report Approval? Yes No
If yes, please submit a photostatic copy of such approval.

3. The successful vendor shall complete an Initial Employee Report, Form AA-302 and submit it to the Division with a \$150.00 Fee and forward a copy of the Form to the Commission. Upon submission and review by the Division, this report shall constitute evidence of compliance with the regulations. Prior to execution of the contract, the EEO/AA evidence must be submitted.

The successful vendor may obtain the Affirmative Action Employee Information Report (AA302) on the Division website www.state.nj.us/treasury/contract_compliance.

The successful vendor(s) must submit the AA302 Report to the Division of Public Contracts Equal Employment Opportunity Compliance, with a copy to Public Agency.

The undersigned vendor certifies that he/she is aware of the commitment to comply with the requirements of N.J.S.A. 10:5-31 and N.J.A.C. 17:27 and agrees to furnish the required forms of evidence.

The undersigned vendor further understands that his/her bid shall be rejected as non-responsive if said contractor fails to comply with the requirements of N.J.S.A. 10:5-31 and N.J.A.C. 17:27.

COMPANY: _____ **SIGNATURE:** _____

PRINT NAME: _____ **TITLE:** _____

DATE: _____

REFERENCES

*The Bidder must supply a minimum of three references.
References must be from jobs similar to this project.*

1. Name of Project: _____
Address: _____
Description of Work: _____
Year Installed: _____
Name of Contact: _____
Phone Number of Contact: _____

2. Name of Project: _____
Address: _____
Description of Work: _____
Year Installed: _____
Name of Contact: _____
Phone Number of Contact: _____

3. Name of Project: _____
Address: _____
Description of Work: _____
Year Installed: _____
Name of Contact: _____
Phone Number of Contact: _____

4. Name of Project: _____
Address: _____
Description of Work: _____
Year Installed: _____
Name of Contact: _____
Phone Number of Contact: _____